



## Eye 2 Stereo Monitor



## Assembly and User's Manual

Rev. Jan. 9/03

Mapletree Audio Design  
Lloyd Peppard  
R. R. 1, Seeley's Bay, Ontario, Canada, K0H 2N0  
(613) 387-3830  
peppardl@post.queensu.ca  
<http://hollowstate.netfirms.com>

© Copyright Lloyd Peppard 2000-2003

## **Introduction**

The Mapletree Audio Design *Eye 2 Stereo Monitor* offers the kit builder a number of unique features:

- ◆ Calibrated, variable sensitivity display of instantaneous signal levels using two type 1629 cathode ray indicator ("magic eye") tubes.
- ◆ A voltage amplifier stage utilizing a 12SC7 dual triode ensures compatibility with signal levels at source, preamplifier, or power amplifier outputs.
- ◆ High (500K Ohms) input resistance for minimal system loading. Dual I/O RCA jacks for simple patching into system.
- ◆ Selection of high speed (instantaneous) or low speed (average) signal display modes.
- ◆ A punched, painted chassis with bottom cover plate.
- ◆ A detachable line cord and back-panel fuse holder.
- ◆ All parts, tubes, hardware, wire, solder, fuses, and knobs provided. Only a few standard tools and a soldering iron are necessary for construction.

## **Before you Start**

Tools required:

- Soldering iron - 40 W min.
- Side cutters
- Long nose pliers
- Pocketknife or wire strippers
- Ruler
- Small adjustable wrench
- Square drive #1 screwdriver
- Philips screwdriver
- Small (1/8") blade screwdriver

Soldering:

- Your soldering iron should have either a pointed or wedge shaped copper tip which must be kept clean and "tinned" at all times. The tip will pit and oxidize through normal use and proper maintenance is essential. If you are using your iron for the first time, apply solder to the tip as soon as it is hot enough to melt. The shiny "tinned" surface will now protect the tip from oxidation. To keep the tip clean during use, wiping on a wet sponge is recommended. To prepare a used tip for use, first file or sand the tip to the desired shape, removing all pitted material and oxidation from the surface. Then proceed to tin the tip as described above. Use only electronic grade solder similar to that supplied which is composed of 40% lead and 60% tin. Silver solder, containing a few percent silver is also acceptable.
- Most of the interconnections are made at solder lugs—on a tube socket, terminal strip, switch, or potentiometer. Every lug has an opening into which the component leads and wires are inserted. While it is not necessary to wrap the wires tightly around the lugs before soldering, a short right-angle bend at the end of each wire will secure it to the lug until all connections can be soldered permanently in place. When all the wires are in place at a particular lug, the instruction to apply solder will be stated as [S(n)] where n is the number of wires and component leads which should be terminated at that point. If the number does not agree with what you see, then you should go back and correct your work before proceeding. When you are ready to make a soldered connection, place the tip of your iron against the lug to heat it and the terminating wires so that solder will melt against them. *Note that solder is applied to the lug and wires, not to the solder tip.* You may however find that the transfer of heat from the tip to the joint is enhanced if a small amount of solder is melted on the tip before applying it to the joint.
- An alternate technique for soldering connections, especially when excessive heat applied to a component is to be avoided (e.g. a rectifier bridge or diode), is to pre-tin

the component lead by applying the tip of the iron to the end of the lead and quickly melting a small amount of solder on the wire. The lead should be held by needle nose pliers which act as a heat sink. A solder lug can also be pre-tinned by applying enough solder to completely fill the hole. Then the pre-tinned lead(s), held by needle nose pliers, is inserted into the lug as the solder is re-melted by application of the iron tip.

- A properly soldered lug connection should be smooth and shiny and solder should fill all voids in the lug, visibly adhering to each wire. Dull looking joints ("cold joints") should be re-heated, a small amount of fresh solder applied, and let cool without any movement of the wires involved. If you are new to soldering, practice with some spare wire and a lug terminal strip is suggested. An extra terminal strip and some wire are supplied for this purpose. The photo below shows a properly soldered lug connection.

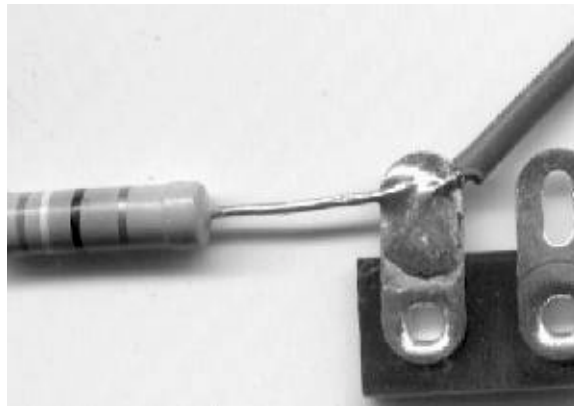

#### Wire:

- The wire supplied is 20 gauge stranded and is used for all interconnections. The wire colors supplied and specified in the instructions make it easier to check your work and to troubleshoot should problems arise later. They are labeled in the wiring diagrams as black (BK), white (W), green (G), and red (R).
- Wire preparation involves cutting to length and stripping the insulation from each end. The lengths of wires are given in the instructions. Unless otherwise stated, the ends of each wire should be stripped to expose 1/4" or slightly less of bare wire using a small pocketknife or wire strippers. This allows for a 1/8" bend in the wire to permit attachment to a solder lug. Keep the strands together by twisting them with your fingers. *When stripping wire, be careful not to cut into the wire strands, which will greatly reduce the current-carrying capability and strength of the wire.*
- *Shielded wire cable* is used where avoidance of noise and hum pickup is essential. It comprises two internal wires (red and white) with a plain copper stranded wire shield around them. To prepare the ends, the outer insulation should be removed, being careful not to cut the strands of the shield. The length of insulation to be removed

should be equal to the longest of the three wires (shield-S, red-R, and white-W) that is required according to the wiring diagram. The wires can then be separated and cut to their individual lengths and the insulation removed from the ends of the red and white wires. The strands of the shield should be twisted together to form a single wire. In all cases, the shield is connected at one end only. It should be clipped off where it emerges from the outer insulation at the other end. The pre-tinning technique is helpful when soldering the fine wires and shield associated with shielded cable. The photo below shows both ends of a length of shielded cable that has been prepared according to the above procedure.

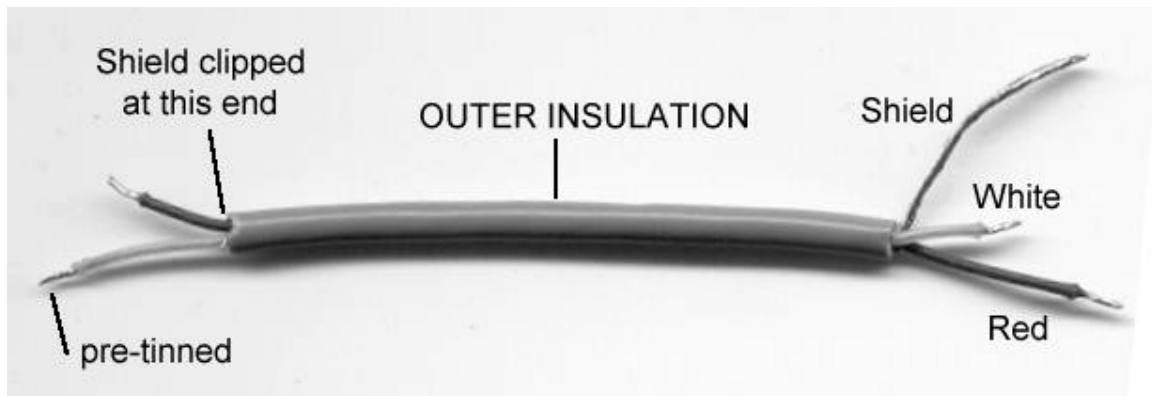

#### Preparation:

- A clear, clean, well-lit work surface is essential for kit assembly. An adjustable lamp, which can be brought close to the work when necessary, is a real advantage. You will need access to an electrical outlet for your soldering iron.
- The chassis has been carefully primed, painted, and baked but the surface can still be damaged by abrasion during assembly. This can be avoided by placing a clean towel or similar covering on the work surface. The chassis will be placed upside down for most of the wiring tasks.
- Layout all the parts and make sure you can identify each one by making an inventory against the parts list at the end of this manual. The resistor values should be identified by matching the colour codes specified in the parts list.
- The assembly will proceed in several phases, each of which represents a reasonable amount of work for one session. For clarity, the wiring diagrams show only the components and connections relevant to a particular phase. The schematic diagram

for the complete circuit is shown at the end of this manual. While it is useful in describing the overall circuit and in identifying the voltages at various points in the circuit, unless you are very experienced, you should assemble the kit following the wiring diagrams rather than the schematic, although they are electrically equivalent. The layout and wiring schemes are designed to yield not only a properly functioning unit but a visually satisfying result as well. It is important to enjoy the assembly process—so take your time!

## **Phase 1: Mechanical Assembly**

In referring to the instructions and wiring diagrams, unless otherwise stated, it is assumed that the chassis is oriented on your work surface (protected by a towel as suggested above) upside down with the front panel (narrow side) toward you. "Up" then refers to the open (bottom) of the chassis and "down" to the top of the chassis. You should check off each of the following steps as you complete them. Refer to Wiring Diagram 1.

- ❑ Mount the 4 RCA jacks (J1a,b and J2a,b) on the rear of the chassis using the gold plated lugs and hex nuts supplied. Orient the solder lugs as shown and bend them out slightly once the nuts have been tightened. Note that the suffix "a" refers to left channel components while "b" refers to the right channel.
- ❑ Mount the right-angle bracket for the octal tube socket for V1 (12SC7) to the wood strip nearest the front of the chassis using two #4 x 1/4" wood screws as shown in the diagram. Orient the bracket so the mounting flange projects toward the front of the chassis.
- ❑ Mount the octal tube socket for V1 (12SC7) to the bracket with two 6-32 x 3/8" machine screws and hex nuts. The socket mounting flange should be on the side of the bracket toward the front of the chassis. *Make sure the socket is oriented with the key pointed left as shown.* Note that the socket lug terminals are numbered clockwise from the key as viewed from the lug side.
- ❑ Mount the AC receptacle J3 on the back panel with two 6-32 x 3/8" machine screws and hex nuts, fastening the ground lug with green wire under one of the nuts as shown. Orient J3 so the center (ground) lug is downward.
- ❑ Mount the fuse holder as shown, tightening the hex nut with a small adjustable wrench or pliers.
- ❑ Mount the AC power switch SW1 by pushing it through the rectangular opening in the center of the front panel with the white dot toward the top of the chassis.
- ❑ Mount potentiometer P2 (Sensitivity Control) and switch SW2 (Speed Selector) on the front panel with the washers under the hex nuts. Tighten the nuts with a small adjustable wrench.
- ❑ Mount the two 1629 magic eye tubes (V2 and V3) to the front wooden strip using the half-round clamps and #4 x 1/4" wood screws as shown in the diagram. The tubes should fit snugly against the holes in the front panel and be oriented with their keys *up* before tightening the clamps. *Do not over-tighten the clamps.*
- ❑ Gently push an octal tube socket onto the base of each of the 1629 tubes. You may have to wiggle the socket back and forth to seat the pins properly.
- ❑ Attach the six 4-lug terminal strips (T1-T6) to the wooden strips at the positions shown using #4 x 1/4" wood screws.
- ❑ Orient transformers TR1 and TR2 on the wood strip toward the rear of the chassis as shown in the diagram. A single bracket secures both transformers to the wood strip with two #4 x 1/4" wood screws as shown in the diagram.

This completes Phase 1. Check your work against the wiring diagram and photograph paying particular attention to the orientation of the tube sockets and transformers.



## **Phase 2: Power and Ground Wiring**

For the following steps, refer to Wiring Diagram 2. In all cases, wires supplying voltage to the tube heaters are twisted together. The twisting of the heater supply wiring will help to reduce any hum induced by the electromagnetic fields generated by the ac currents. When asked to "prepare" a length of wire, it means to cut it to the length specified and remove approximately 1/4" of insulation from each end. You may find it advantageous to "pre-tin" the ends of the wire by melting a bit of solder on them before insertion in the solder lugs.

- ❑ Connect the free end of the green wire attached to the ground lug under the ac jack mounting screw to lug 2 (center) of ac jack J3 [S(1)].
- ❑ Prepare a 1" length of black wire. Connect it between terminals 2 and 4 of transformer TR1. Crimp the ends of the wires around the transformer terminals to hold them in place.
- ❑ Prepare a 2" length of black wire. Connect it between terminals 1 and 3 of TR1.
- ❑ Prepare a 1" length of black wire. Connect it between terminals 2 and 4 of transformer TR2.
- ❑ Prepare a 2" length of black wire. Connect it between terminals 1 and 3 of TR2.
- ❑ Prepare a 2" length of black wire and connect it between lug 3 of J3 [S(1)] and terminal 1 of TR1 [S(2)].
- ❑ Prepare a 1" length of black wire. Connect it between terminal 3 of transformer TR1 [S(2)] and terminal 1 of TR2 [S(2)].
- ❑ Prepare a 2" length of black wire and connect it between terminal 4 of TR1 [S(2)] and terminal 2 of TR2 [S(2)].
- ❑ Prepare a 3" length of black wire and connect it between lug 2 of the fuse holder FU1 [S(1)] and terminal 2 of TR1 [S(2)].
- ❑ Prepare a 2" length of red wire and connect it between terminals 6 and 7 of TR1. Solder both connections.
- ❑ Prepare a 2" length of green wire and connect it between terminals 6 and 7 [S(1)] of TR2.
- ❑ Prepare two 2" lengths of red wire. Connect one length between terminal 5 of TR1 [S(1)] and lug 2 of terminal strip T2 [S(1)]. Connect the other length between terminal 8 of TR1 [S(1)] and lug 3 of T2 [S(1)].
- ❑ Prepare a 3" length of red wire and connect it between terminals 1 of terminal strip T2 and terminal 4 of terminal strip T1.
- ❑ Prepare a 3" length of black wire and connect it between lug 4 of T2 and lug 2 of T1.
- ❑ Prepare a 2" length of black wire and connect it between terminal 6 of TR2 [S(2)] and lug 4 of terminal strip T2.
- ❑ Prepare a 4" length of black wire and connect it between lug 4 of T2 [S(3)] and lug 4 of T4.
- ❑ Prepare a 4" length of black wire and connect it between lug 2 of T1 and the ground lug of input jack J1a [S(1)].

- ❑ Locate electrolytic capacitor C4 (33uF/450V) and note the minus signs with arrows running down one side denoting the negative lead. Trim the leads as necessary and connect the negative lead to lug 2 of T1 and the positive lead to lug 4 of T1 [S(2)].
- ❑ Locate resistor R5 (18K brown-gray-orange) and trim the leads as necessary to connect between lug 1 of T2 [S(2)] and lug 1 of T1 as shown. To ensure a good solder connection, scrape the ends of the leads of R5 with a pocket knife to remove any oxidation buildup.
- ❑ Connect a short length of bare wire between lugs 2 [S(4)] and 3 of T1.
- ❑ Locate electrolytic capacitor C5 (33uf/450V) and note the minus signs with arrows running down one side denoting the negative lead. Trim the leads as necessary and connect the negative lead to lug 3 of T1 [S(2)] and the positive lead to lug 1 of T1.
- ❑ Prepare a 6" length of red wire and connect one end to lug 1 of T1 [S(3)] and the other end to lug 4 of T6.
- ❑ Check that all lugs of terminal strips T1 and T2 have been soldered. You should have applied enough solder so the holes in the lugs are completely filled with solder. You will now proceed to re-solder the lugs of T2 as you insert the pre-tinned leads of diodes D1-D4 as described below.
- ❑ Locate the four 1N4007 silicon diodes D1-D4. Trim the leads of two of the diodes to 1/2" and the other two to 3/4". Holding the leads with long-nose pliers near the body of the diode, pre-tin the end of each lead by heating the end of the lead with your iron and melting solder onto the wire.
- ❑ Connect one of the diodes with 1/2" leads between lugs 1 and 2 of terminal strip T2 by re-melting the previously applied solder and pushing the diode leads into the lugs with long-nose pliers. *Make sure the banded end connects to lug 1 as shown in the diagram.* Do the same with the other diode with the 1/2" leads, connecting it between lugs 3 and 4 of T2 *with the banded end connected to lug 3.*
- ❑ Connect one of the diodes with 3/4" leads between lugs 1 and 3 of terminal strip T2 by re-melting the previously applied solder and pushing the diode leads into the lugs with needle nose pliers. *Make sure the banded end connects to lug 1 as shown in the diagram.* Do the same with the other diode with the 3/4" leads, connecting it between lugs 2 and 4 of T2 *with the banded end connected to lug 2.*
- ❑ Double-check all the connections to terminal strips T1 and T2 with the aid of the wiring diagram.
- ❑ Cut two black wires 19" long and twist them together tightly for their entire length. Strip the wires at one end and connect them to the two lugs of the power switch SW1 at the front of the chassis. Solder both lugs.
- ❑ Route the twisted pair back along the corner of the chassis as shown and trim and strip the remaining leads to connect one lead to lug 1 of ac jack J3 [S(1)] and the other to terminal 1 of fuse holder FU1 [S(1)].
- ❑ Prepare and twist together two 4" green wires. Connect the wires at one end to terminals 5 [S(1)] and 8 [S(1)] of transformer TR2. Connect the wires at the other end of the twisted pair to lugs 1 and 2 of terminal strip T3.
- ❑ Prepare two green wires 7-1-2" long and twist them together. Connect the leads at one end to lugs 1 and 2 of terminal strip T3 and at the other end to lugs 1 and 2 of T6.

- ❑ Prepare two green wires 7-1/2" long and twist them together. Connect the leads at one end to lugs 1 and 2 of T6 and at the other end to lugs 7 [S(1)] and 8 [S(1)] of the tube socket for V1 as shown.
- ❑ Prepare a 5" long black wire and connect one end to lug 4 of T5 and the other to lug 6 of the socket for V1 as shown.
- ❑ Connect a jumper of bare wire between lug 1 of V1 and lug 6 of V1 as shown.
- ❑ Prepare a 2-1/2" black wire with one end stripped back 1/2". Connect the 1/2" stripped end to lugs 3 of both sections of potentiometer P1 as shown. Solder both connections. Connect the other end of this wire to lug 6 of V1 [S(3)].
- ❑ Prepare a 4" black wire and connect one end to lug 4 of T5 and the other to lug 4 of T4 as shown.
- ❑ Prepare a 2-1/2" black wire and connect one end to lug 1 of V1 [S(2)] and the other end to lug 1 of switch SW2b as shown. Note that this switch has 4 sections, two of which are not used. The six outer lugs of the two sections that are used are bent outwards for easy identification. Lug 4 is located below lug 2 for each section.
- ❑ Prepare a 1" black wire and connect one end to lug 1 of SW2b [S(2)] and the other end to lug 1 of SW2a [S(1)].
- ❑ Prepare a 7-1/2" red wire and connect it between lug 4 of T6 and lug 4 of T3.
- ❑ Locate resistor R4b (1M Ohm brown-black-black-yellow) and trim the leads to 3/4".
- ❑ Connect this resistor between lugs 3 [S(1)] and 4 of the tube socket for V3.
- ❑ Prepare a 3" length of red wire and connect one end to lug 4 of V3 [S(2)] and the other end to lug 4 of T3 [S(2)]. There should be enough length in this wire and the other wires to be connected to V3 and V2 to enable removal of the sockets when replacing the 1629 tubes.
- ❑ Prepare a 3" length of black wire and connect one end to lug 8 of V3 [S(1)]. Connect the other end to lug 4 of T4.
- ❑ Prepare a 3" green wire and connect between lug 5 of V3 [S(1)] and lug 3 of T3.
- ❑ Cut two 3" green wires and twist them together. Connect the wires at one end to lug 1 [S(3)] and lug 2 [S(3)] of T3 and the wires at the other end to lugs 2 [S(1)] and 7 [S(1)] of V3.
- ❑ Group together the wires going to lugs 2, 4, 5, 7, and 8 of V3 and tie them securely with a cable tie about 1" from the socket as shown.
- ❑ Locate resistor R4a (1M Ohm brown-black-black-yellow) and trim the leads to 3/4".
- ❑ Connect this resistor between lugs 3 [S(1)] and 4 of the tube socket for V2.
- ❑ Prepare a 3" length of red wire and connect one end to lug 4 of V2 [S(2)] and the other end to lug 4 of T6 [S(3)].
- ❑ Prepare a 3" length of black wire and connect one end to lug 8 of V2 [S(1)]. Connect the other end to lug 4 of T5.
- ❑ Prepare a 3" green wire and connect between lug 5 of V2 [S(1)] and lug 3 of T6.
- ❑ Cut two 3" green wires and twist them together. Connect the wires at one end to lug 1 [S(3)] and lug 2 [S(3)] of T6 and the wires at the other end to lugs 2 [S(1)] and 7 [S(1)] of V2.
- ❑ Group together the wires going to lugs 2, 4, 5, 7, and 8 of V2 and tie them securely with a cable tie about 1" from the socket as shown.

This completes Phase 2, the power and ground wiring. Double-check your work against the wiring diagram. Make sure all of the solder joints are clean and shiny and that solder fills each lug, leaving no voids.

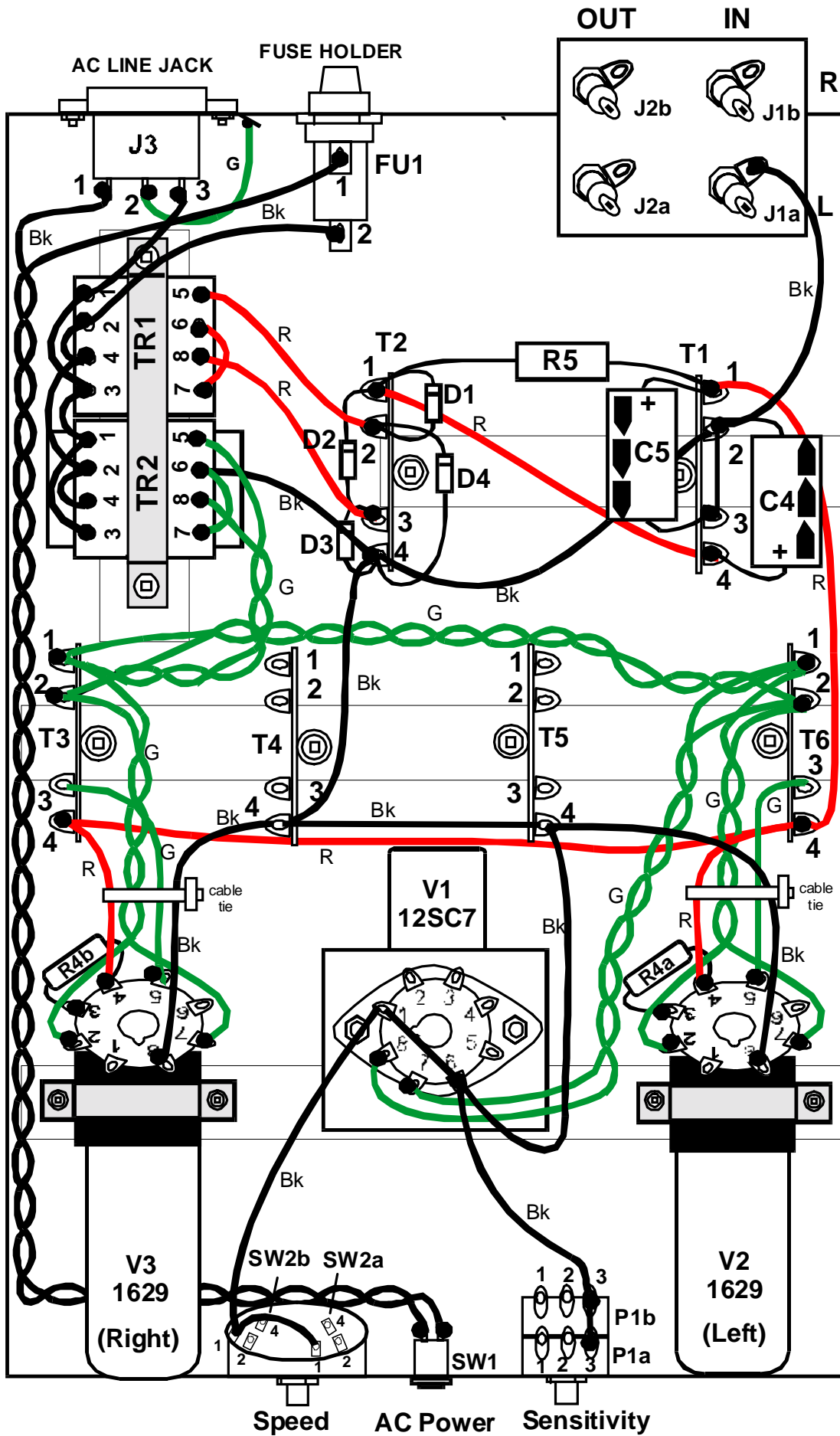

WIRING DIAGRAM 2

### **Phase 3: Signal Wiring**

Refer to Wiring Diagram 3 for the following steps. Only those connections to be made in this phase are highlighted. In some cases, you will be asked to add a wire to a previously soldered lug or terminal. This will be noted as "re-solder" or [RS(n)] where n is the total number of wires at that point. It is recommended that you pre-tin wires or component leads which are to be added to previously soldered connection points.

- ❑ Prepare a 1-1/2" length of green wire and connect it between the center lug of jack J2a [S(1)] and the center lug of jack J1a [S(1)].
- ❑ Prepare a 1-1/2" length of red wire and connect it between the center lug of jack J2b [S(1)] and the center lug of jack J1b [S(1)].
- ❑ Pre-tin the solder lug of jack J1b.
- ❑ Locate the pre-cut 14" length of 2-conductor shielded cable. Carefully remove 1" of outer (gray) insulation from each end. At one end, separate the copper shield wire from the red and white conductor wires and twist the copper strands together. At the other end clip off the copper shield so no strands are left exposed.
- ❑ Strip the ends of the red and white conductor wires at each end of the shielded cable by about 1/8" and pre-tin each one.
- ❑ At the end with the shield wire, connect the red conductor wire to the center lug of jack J1b [RS(2)] and the white wire to the center lug of jack J1a [RS(2)]. Solder the shield to the ground lug of J1b.
- ❑ Route the shielded cable along the edge of the chassis as shown and under tube V2.
- ❑ Locate the two orange capacitors C1a and C1b (0.1uF/400V). Cut their leads to 1/2". Referring to the wiring diagram, connect one lead of C1a to lug 1 of potentiometer section P1a [S(1)]. Make a small (approx. 1/8") loop in the other lead of C1a with your long-nose pliers and pre-tin this loop.
- ❑ Connect one lead of C1b to lug 1 of potentiometer section P1b [S(1)]. Make a small (approx. 1/8") loop in the other lead of C1b with your needle nose pliers and pre-tin this loop.
- ❑ Solder the pre-tinned white conductor wire of the shielded cable to the loop in the lead of capacitor C1a. Solder the pre-tinned red conductor wire of the shielded cable to the loop in the lead of capacitor C1b.
- ❑ Prepare a 6" length of red wire. Connect one end to lug 5 of V1 [S(1)] and the other end to lug 3 of terminal strip T4.
- ❑ Prepare a 6" length of green wire. Connect one end to lug 2 of V1 [S(1)] and the other end to lug 3 of terminal strip T5.
- ❑ Prepare a 3" length of green wire. Connect one end to lug 2 of P1a [S(1)] and the other end to lug 3 of V1 [S(1)].
- ❑ Prepare a 2" length of red wire. Connect one end to lug 2 of P1b [S(1)] and the other end to lug 4 of V1 [S(1)].
- ❑ Prepare a 6" length of red wire. Connect one end to lug 4 of switch section SW2b [S(1)] and the other end to lug 3 of terminal strip T3.
- ❑ Prepare a 8" length of green wire. Connect one end to lug 4 of switch section SW2a [S(1)] and the other end to lug 3 of terminal strip T6, routed as shown.

- ❑ Use two cable ties to pull together the 3 wires (2 red, 1 green) running along the left side of V1 as shown.
- ❑ Use a cable tie to pull together the green and black wires running along the right side of V1 as shown. Do not bundle in the twisted green wires in this tie.
- ❑ Locate capacitors C3a and C3b (0.18uF/200V) and trim their leads to ¾". Twist the leads of the two capacitors together at one end. Solder this junction and trim off the excess leads. Prepare a 1-1/2" length of black wire and solder one end to this junction between the two capacitors.
- ❑ Connect the remaining lead of C3b to lug 2 of SW2b [S(1)] and the remaining lead of C3a to lug 2 of SW2b [S(1)]. Connect the black wire running from the capacitor junction to lug 1 of SW2a [RS(2)].
  
- ❑ This completes the wiring of the front portion of the chassis (ahead of the terminal strips T3-T6). Take time now to check all your connections against the wiring diagram.
  
- ❑ Locate resistors R1a and R1b (180K brown-gray-yellow). These resistors are positioned under the cabled wires running to V2 and V3. Trim the leads as necessary and connect one end of R1b to lug 4 of T3 [RS(3)]. Slip insulation tubing over the other end and connect it to lug 3 of T4.
- ❑ Connect one end of R1a to lug 4 of T6 [RS(4)]. Slip insulation tubing over the other end and connect it to lug 3 of T5.
- ❑ Locate resistors R3a and R3b (39K orange-white-orange). These resistors are positioned under the cabled wires running to V2 and V3. Trim the leads as necessary and connect one end of R3b to lug 3 of T3 [S(3)] and the other end to lug 2 of T4.
- ❑ Connect one end of R3a to lug 3 of T6 [S(3)] and the other end to lug 2 of T5.
- ❑ Locate capacitors C2a and C2b (0.082uF/200V). Trim the leads of C1b as necessary and connect one end to lug 3 of T4 [S(3)] and the other end to lug 2 of T4.
- ❑ Trim the leads of C1a as necessary and connect one end to lug 3 of T5 [S(3)] and the other end to lug 2 of T5.
- ❑ Locate resistors R2a and R2b (2M red-black-green). Trim the leads as necessary and connect one lead of R2b to lug 4 of T4 [RS(4)] and the other lead to lug 2 of T4 [S(3)].
- ❑ Connect one lead of R2a to lug 4 of T5 [RS(4)] and the other lead to lug 2 of T5 [S(3)].
- ❑ Locate the two remaining diodes D5a and D5b. Trim the leads to ¾". Gripping the leads next to the diode body with long-nose pliers, pre-tin the ends of each lead.
- ❑ Connect the *banded end* of D5b to lug 4 of T4 [RS(5)] and the other end to lug 2 of T4 [RS(4)].
- ❑ Connect the *banded end* of D5a to lug 4 of T5 [RS(5)] and the other end to lug 2 of T6 [RS(4)].
- ❑ Use a cable tie to pull together the 3 wires (black, red, and green) running along the chassis behind V1 as shown.

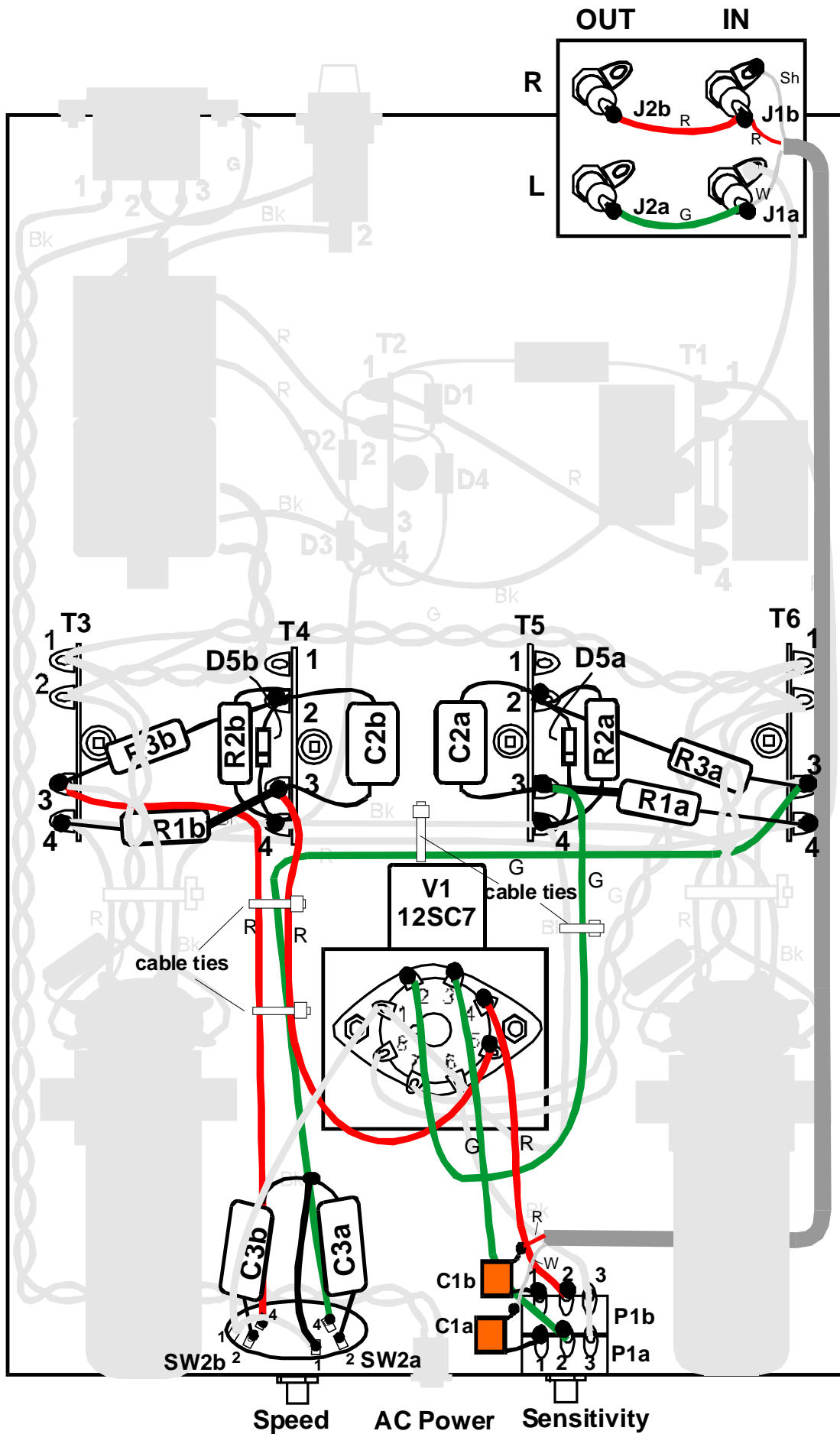

**WIRING DIAGRAM 3**

- This completes the wiring of your Eye 2 kit. Take time to re-check all connections against the wiring diagrams. Take special note that the number of wires at each solder lug of the six terminal strips are as given in the following list.

Terminal strip T1:

Lug 1 - 3

Lug 2 - 4

Lug 3 - 2

Lug 4 - 2

Terminal strip T2:

Lug 1 - 4

Lug 2 - 3

Lug 3 - 3

Lug 4 - 5

Terminal strip T3:

Lug 1 - 3

Lug 2 - 3

Lug 3 - 3

Lug 4 - 3

Terminal strip T4:

Lug 1 - 0

Lug 2 - 4

Lug 3 - 3

Lug 4 - 5

Terminal strip T5:

Lug 1 - 0

Lug 2 - 4

Lug 3 - 3

Lug 4 - 5

Terminal strip T6:

Lug 1 - 3

Lug 2 - 3

Lug 3 - 3

Lug 4 - 4

#### **Phase 4: Checkout and final assembly**

Once you have visually verified that your kit is wired correctly, you are ready to perform a simple checkout procedure.

- ❑ If you have or can borrow a multimeter, make a reading of the resistance from lug 1 of T1 to ground (lug 2 of T1). It should climb to several thousand Ohms as the filter capacitors charge up with the small voltage applied by your meter.
- ❑ Insert a 0.5 A fuse into the fuse holder and attach the line cord to the ac line jack at the rear of the chassis.
- ❑ If you have a multimeter, switch it to measure the dc voltage from lug 1 of T1 (+) to lug 2 of T1 (-).
- ❑ Press the end of the rocker switch with the white dot to turn the power on. The voltage reading should climb to over +300 VDC, then decline to around +275 VDC as the tube heaters warm up and the tubes draw plate current.
- ❑ Check that both eye tubes are glowing green with a 90 degree shadow sector visible.
- ❑ Connect a signal source to the input jacks on the rear of the chassis (for checkout, the output from a CD player is convenient).
- ❑ With the signal source active and the *Speed* switch in the OFF position, the shadow sectors of both eye tubes should remain at 90 degrees regardless of the setting of the *Sensitivity* control.
- ❑ Turn the *Speed* switch to the LO position. You should be able to close the eye on music peaks as the *Sensitivity* control is turned clockwise. The eye shadow sectors of both tubes should open and close with the signal intensity in each channel.
- ❑ Turn the *Speed* switch to the HI position. The sensitivity should increase and the opening and closing of the shadow sector be much more rapid than for the LO speed setting.

If you experience problems, start by checking for "cold" solder joints in which one or more wires may not be making a good electrical connection. Re-heat these joints and add a bit more solder. You can also check the voltages at various points in the circuit as shown in the schematic diagram. Voltages should be within 10% of those shown. This may help pinpoint the source of trouble.

Feel free to contact Mapletree Audio Design for help at any point in the assembly and checkout of your kit or should any future servicing problems arise.

- ❑ Attach the bottom cover plate to the chassis with four 6-32 sheet metal screws.
- ❑ Attach the four rubber feet to the corners of the bottom plate.

## Operating Suggestions

The parallel input/output jacks permit patching the Eye 2 Stereo Monitor into your system at any point (output of a signal source, preamp, or power amp). Connect the output you wish to monitor to the Eye 2 input jacks and connect the component being fed by this signal to the Eye 2 output jacks as shown below.

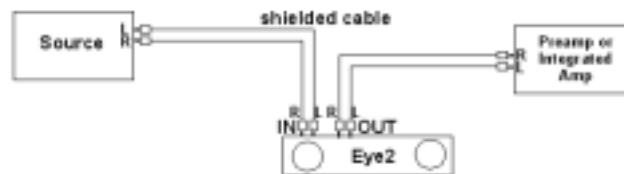

**Source Output Monitoring**

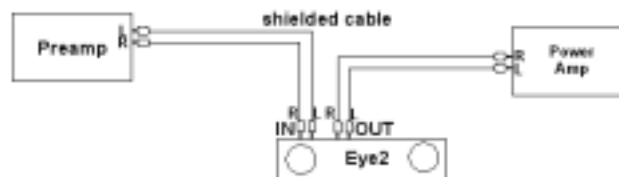

**Preamp Output Monitoring**

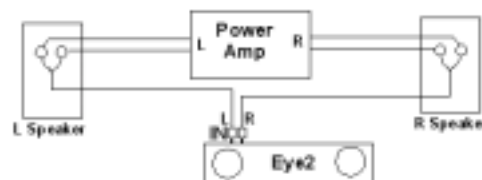

**Power Amp Output Monitoring**

The resistive loading is 500K Ohms, which should not affect the operation of your system. As with any component, there is a capacitive load presented by the Eye 2, which can be minimized by avoiding the use of patch cables longer than necessary to make the desired connections.

If you connect the Eye 2 to your power amplifier outputs (in parallel with your speakers), the calibration points on the *Sensitivity* control show the approximate instantaneous power (assuming an 8 Ohm speaker load) required to just close the eye. No damage is done to the eye tubes by driving with excess signal beyond the point of closure.

The bottom plate is perforated to provide ventilation for the tubes. Make sure there is free circulation of air around the chassis to avoid excessive heat buildup. The tubes should have a long lifetime but the eye tubes may eventually grow dimmer with time as the phosphor becomes chemically contaminated. Replacement requires removal of the

clamps holding down the tube, followed by careful removal of the socket. Check that the base key of the new tube is oriented properly to ensure the shadow sector is centered on the eye tube face. The 12SC7 and 1629 tubes are available as new old stock (NOS) and should be readily obtainable for the foreseeable future. A recommended supplier is Antique Electronic Supply, 6221 S Maple Ave, Tempe, Arizona 85283 (480) 820-5411 ([www.tubesandmore.com](http://www.tubesandmore.com)). If you have difficulty obtaining replacement tubes, contact Mapletree Audio Design.

## **Appendices**

Parts List

Schematic Diagram

Circuit Description

Specifications

## Parts List

Reference	Description	Quantity
C1a,b	0.1uF/400V mylar capacitor	2
C2a,b	0.082uF/200V mylar capacitor	2
C3a,b	0.18uF/200V mylar capacitor	2
C4, C5	33uF/450V electrolytic capacitor	2
D1–D4, D5a,b	1N4007 1000V/1A diode	6
FU1	0.5A/250V fuse	2
J1a,b, J2a,b	RCA gold plated phono jack	4
J3	IEC ac receptacle	1
P1a,b	500K dual linear potentiometer (sensitivity)	1
R1a,b	180K 1W resistor (brown-gray-yellow)*	2
R2a,b	2M 1W resistor (red-black-green)	2
R3a,b	39K 1W resistor (orange-white-orange)	2
R4a,b	1M ½ W 1% resistor (brown-black-black-yellow)	2
R5	18K 1W resistor (brown-gray-orange)	1
SW1	SPST switch (power)	1
SW2	3 position 4 pole rotary switch (2 poles used)	1
T1–T6	4-lug terminal strip	6
TR1	Power transformer 230 VAC/25 mA	1
TR2	Filament transformer 12.6 VCT/0.45 A	1
V1	12SC7 tube	2
V2, V3	1629 tube	2
	Tube socket-octal type	3
	Punched, drilled, and painted aluminum chassis	1
	Aluminum chassis bottom plate	1
	Knob 23 mm	2
	Fuse holder	1
	Rubber feet	4
	Line cord	1
	Transformer TR1/TR2 mounting bracket	1
	Tube socket V1 angle mounting bracket	1
	Eye tube mounting clamps	2
	Ground lug with attached wire	1
	6-32 3/8" machine screws/nuts	4
	#6 sheet metal screws (for chassis bottom plate)	4
	#4 1/4" wood/metal screws	14
	Solder	10 ft
	Red hookup wire	3 ft
	Green hookup wire	3 ft
	Black hookup wire	3 ft
	Shielded cable (2-wire plus shield)	14"
	Cable ties	6
	Bare wire	4"
	Insulation tubing	6"
	Instruction Manual	1

\* 4<sup>th</sup> band on all resistors may be silver or gold

# Schematic Diagram

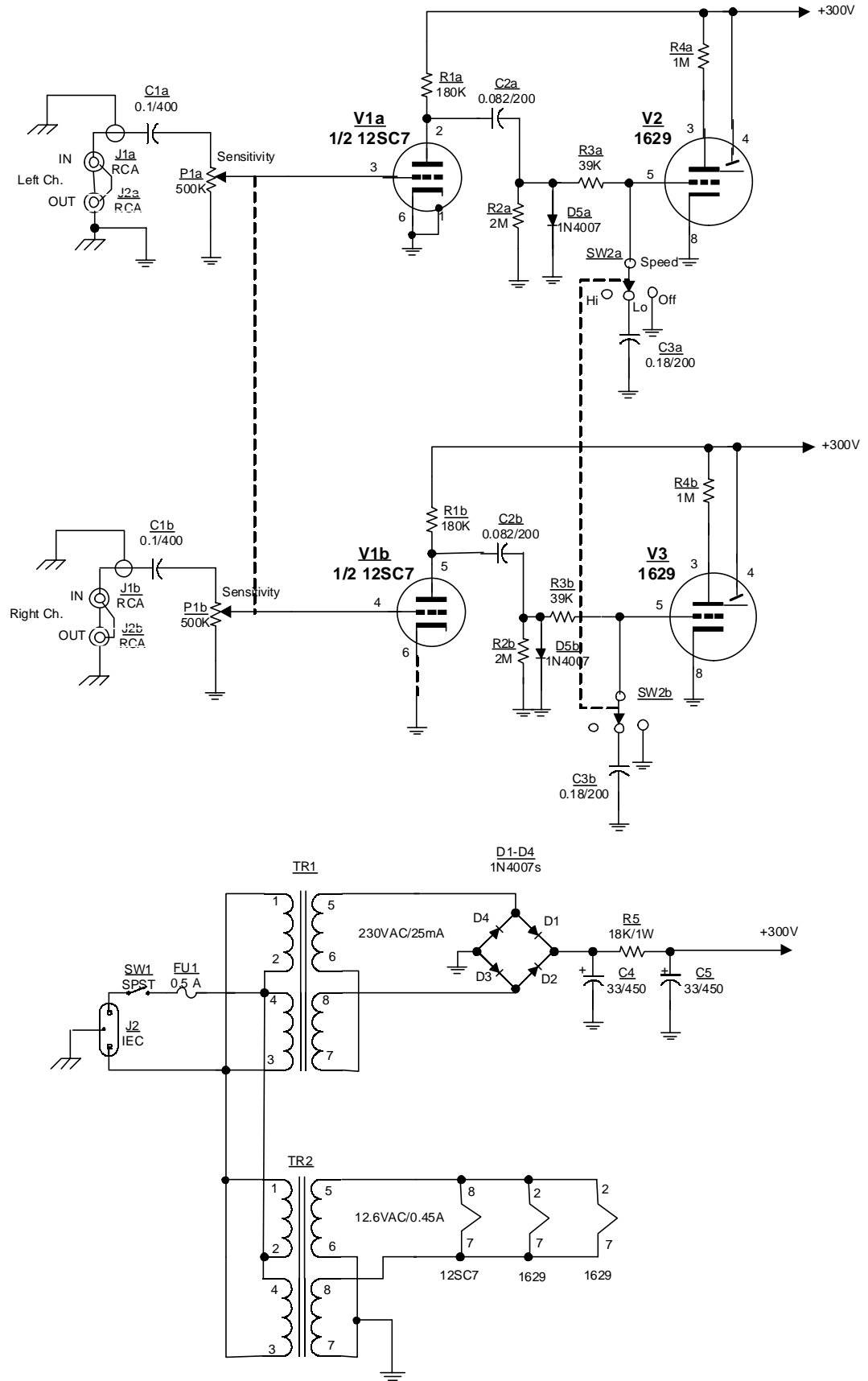

## **Circuit Description**

The signals to be monitored are connected to the input jacks J1a and J1b. The output jacks J2a and J2b feed the signal back to the system. The following describes the left channel operation; the right channel is identical. Capacitor C1a blocks any dc voltage that may be present on the signal being monitored and couples the signal component through the sensitivity potentiometer P1a to the grid of V1a. The 12SC7 (V1a,b) is a dual high-mu triode with a cathode common to both sections. It is used as a common-cathode voltage amplifier with the output taken from the plate and coupled through capacitor C2a to the next stage. Resistor R2a and diode D5a form a half-wave rectifier circuit whose output is the portion of the signal waveform more negative than about 0.5 V (the diode cut-in voltage). This signal is connected through R3a to the grid of the eye tube V2. With the speed switch in the LO position, resistor R3a and capacitor C3a form a low-pass filter which reduces the sensitivity of the eye tube to rapid changes in the input signal. The effective RC time constant associated with this filter is about 5 ms. The triode section of V2 is a dc amplifier which further increases the signal level and applies it internally to the eye control electrode. The high voltage applied to the target electrode of V2 (pin 4) creates a flow of electrons from the cathode (pin 8) and illuminates the phosphor coating on the target (the visible portion of the eye). With zero signal voltage applied to the input grid (pin 5), the control electrode blocks the electron flow to the target in a 90-degree "shadow sector". As the grid voltage amplitude increases (in a negative direction), the positive voltage on the control electrode produces a reduced shadow sector angle visible on the target. At high signal levels, the shadow sector disappears and the "eye" appears to close. Further increases in signal produce a slight "overlapping" of the shadow sector edges producing increased target illumination over a small angle. Since the voltage across a speaker resistive load of 8 Ohms can be calculated, the sensitivity control is calibrated in terms of the instantaneous power required to just close the eye (reduce the shadow sector angle to zero). This is only effective with the speed control in the HI position where high-speed transients are visible.

The power supply provides a B+ voltage of about +300 V through a full-wave rectifier bridge (D1–D4) and CRC filter (C4–R5–C5). The tube heaters are supplied with 12.6 VAC from transformer TR2.

## **Specifications**

**Connections:** parallel RCA jacks for convenient patching into system at any point.

**Input resistance:** 500K Ohms at 1 kHz.

**Sensitivity (fast mode):** 80 mV at 1 kHz.

**Calibrated power points for eye closure (fast mode):** 0.01, 0.1, 1, and 10 Watts.

**Time constant (slow mode):** approx. 5 ms.

**Dimensions:** 8" x 12" x 2"